









*Note: Product may vary slightly from image shown.*

## SPECIFICATIONS

**240V 3HP 13A PH1 60Hz**

15,000 lbs lifting capacity  
Overhead Design

## FEATURES

-  **15,000 lbs Lifting Capacity**  
Capacity maintained with arms fully extended.
-  **Automatic Safety Locks**  
Equipped with single point lock for ease of use and safety.
-  **High Polymer Slide Blocks**  
Polyethylene wear resistant slide blocks ensure longevity.
-  **Dual Direct Drive**  
Reliable dual direct drive hydraulic cylinders for powerful lifting.
-  **Versatile Arms & Pads**  
Three stage front arms and rear arms, screw up pads, and standard truck adapters.
-  **Vehicle Protection**  
Rubber door guards and height limit switch.
-  **Durable Finish**  
Powder coat finish for maximum durability.

**Please Note: 2ft Height Extension Kit comes WITH this lift.**

# SPECIFICATIONS

LTPO15 | 15,000 LBS 2-POST OVERHEAD LIFT

## POWER REQUIREMENTS

240V 3HP 13A PH1 60Hz

## SHIPPING INFORMATION

Lift Unit: 155" x 25" x 40" (2700 lbs)

Pump Unit: 31" x 11" x 12" (60 lbs)

Optional Height Kit: 26" x 12" x 18" (200 lbs)

## TECHNICAL CLEARANCES & DIMENSIONS

FRONT PROFILE

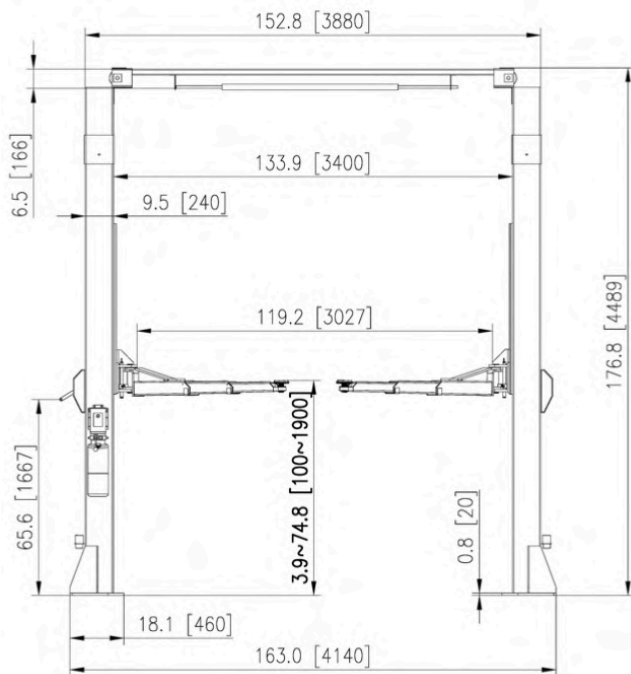

TOP & SIDE PROFILES

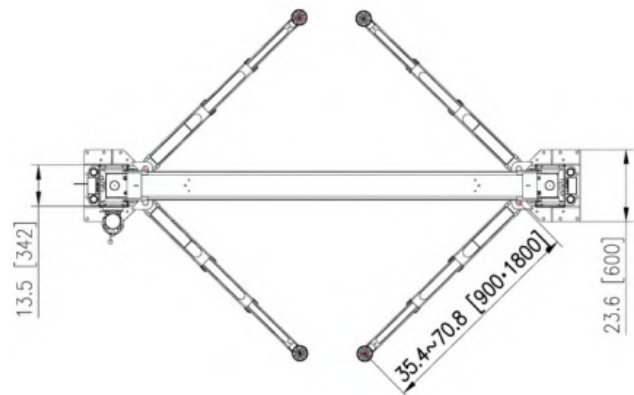

Please note, this blueprint shows the height extension kit on the LTPO15 lift. This Lift COMES WITH a height kit and the lift MUST be assembled with the height kit. The cables and hoses that come with this lift will only fit if the height kit is installed.

DIMENSIONS, COLOURS AND ITEMS ARE SUBJECT TO CHANGE WITHOUT PRIOR NOTICE DUE TO OUR CONTINUOUS IMPROVEMENT PROGRAM.

**Daytona**

101 Applewood Dr, Brighton, ON K0K1H0

☎ 1-866-219-9991 / 613-475-5400

✉ [customercare@daytonaproducts.com](mailto:customercare@daytonaproducts.com)

🌐 [www.daytonaproducts.com](http://www.daytonaproducts.com)