



Note: Product may vary slightly from image shown.



PRECISION ALIGNMENT READY

Engineered for commercial auto repair facilities demanding precision and heavy-duty lifting. Features built-in slip plates, adjustable turntables, and an ultra-wide runway to accommodate a vast range of vehicles.

IDEAL FOR:

- ✓ Alignment Centers
- ✓ Dealership Service Centers
- ✓ Heavy Duty & Fleet Maintenance

SYSTEM FEATURES

-  **24,000 lbs Lifting Capacity**
Powered by a large heavy duty 5" cylinder and aircraft quality lifting cables.
-  **Ladder Lock System**
Manual release with locking positions every 3.5" starting at 21".
-  **Alignment Configuration**
Built in slip plates and adjustable turntables included standard.
-  **Industrial Grade Finish**
Matted powder coat finish in dark Grey for lasting durability.

- Tilting approach ramps in bright Orange
- 25.5" runway accommodates various vehicle widths
- Will accommodate most dual rear wheel pick up trucks

PLEASE NOTE

Lift only - Wheel Alignment Computer is sold separately. Rolling Jacks are sold separately.

SPECIFICATIONS

LFA24 | 24,000 LBS 4-POST ALIGNMENT LIFT

POWER REQUIREMENTS

240V 4HP 15Amp 1 Ph 60Hz

KEY DIMENSIONS

Overall Length:	330.5"
Overall Width:	155.1"
Overall Height:	87.9"
Clearance:	69.3" (under runway at full height)

SHIPPING INFORMATION

Lift Dimensions: 278" x 33" x 65"

Shipping Weight: 7,800 lbs

Pump: Attached to lift. Included in dimensions.

RUNWAY SPECIFICATIONS

Runway Dimensions: 25.6" Width x 284.6" Length

Inner Width: 43.7" (between runways)

TECHNICAL CLEARANCES & DIMENSIONS

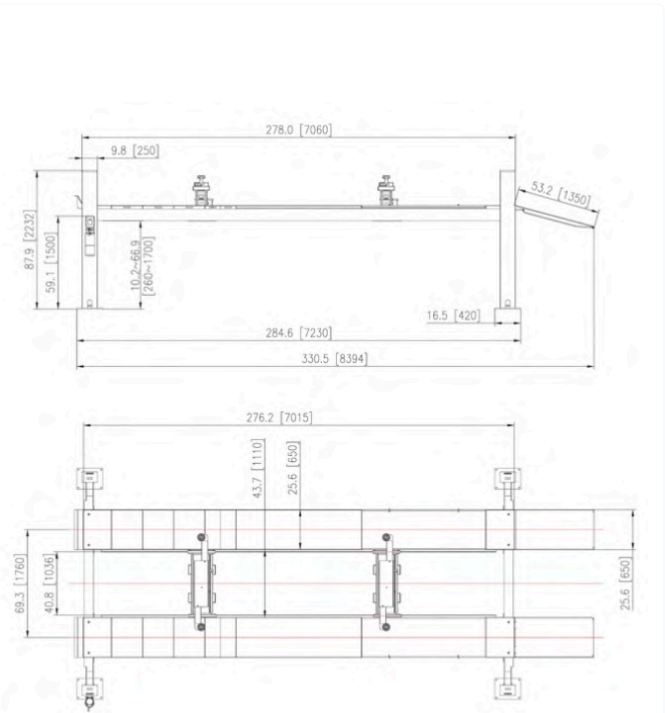
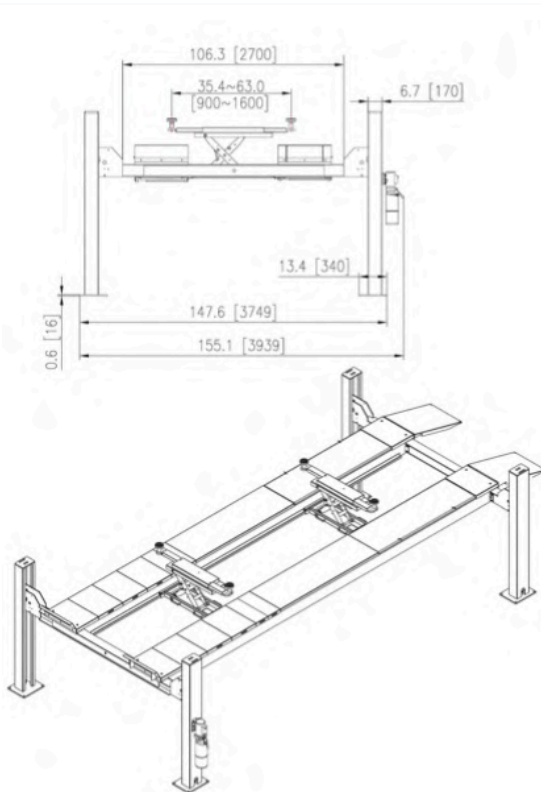

DIMENSIONS, COLOURS AND ITEMS ARE SUBJECT TO CHANGE WITHOUT PRIOR NOTICE DUE TO OUR CONTINUOUS IMPROVEMENT PROGRAM.

