



Note: Product may vary slightly from image shown.

PRECISION ALIGNMENT READY

Engineered for commercial auto repair facilities demanding precision and heavy-duty lifting. Features built-in slip plates, adjustable turntables, and an ultra-wide runway to accommodate a vast range of vehicles.

IDEAL FOR:

- ✓ Alignment Centers
- ✓ Dealership Service Centers
- ✓ Heavy Duty & Fleet Maintenance

SYSTEM FEATURES

-  **12,000 lbs Lifting Capacity**
Powered by a large heavy-duty 5" cylinder and aircraft quality lifting cables.
-  **Ladder Lock System**
Manual release with locking positions every 3.5" starting at 21".
-  **Alignment Configuration**
Built-in slip plates and adjustable turntables included standard.
-  **Industrial Grade Finish**
Matted powder coat finish in dark Grey for lasting durability.

- Tilting approach ramps in bright orange
- 25.5" runway accommodates various widths
- Accommodates most dual rear wheel pickups
- Rise Time / Drop Time: 110s

PLEASE NOTE

Lift only - Wheel Alignment Machine is sold separately. Rolling Jack is sold separately.

SPECIFICATIONS

LPPA12 | 12,000 LBS 4-POST ALIGNMENT LIFT

POWER REQUIREMENTS

240V 4HP 15A PH1 60Hz

KEY DIMENSIONS

Overall Length:	236.5" (inc. Post Bases)
Overall Width:	143.5" (inc. Post Bases)
Overall Height:	101"
Clearance:	69" (under runway at full height)

SHIPPING INFORMATION

Lift Dimensions: 229" x 30" x 44"

Shipping Weight: 4,490 lbs

Pump: Attached to lift. Included in dimensions.

RUNWAY SPECIFICATIONS

Runway Dimensions: 25.5" Width x 217.25" Length

Runway Span: 95"

Inner Width: 125" (inside posts)

Inner Length: 210.25" (inside posts)

Note: Pump sticks out 14" from Post. Post Dimensions: 9.75" x 6.75".

TECHNICAL CLEARANCES & DIMENSIONS

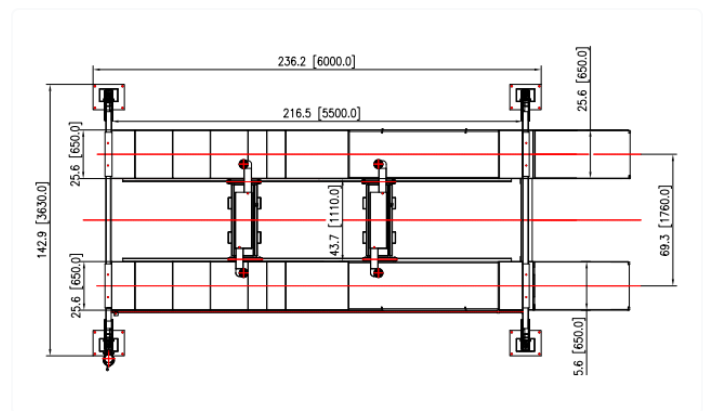
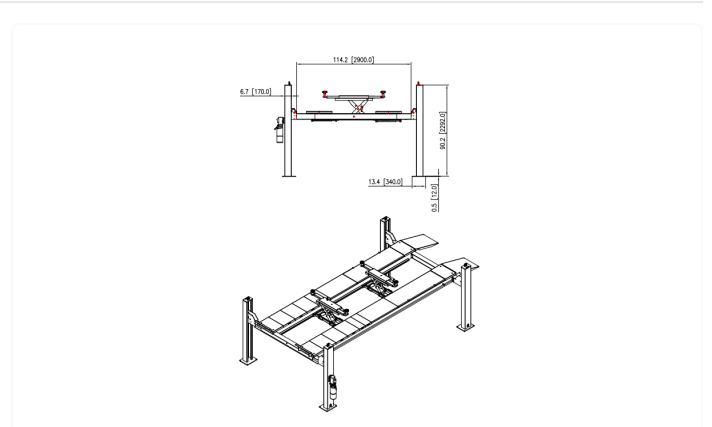
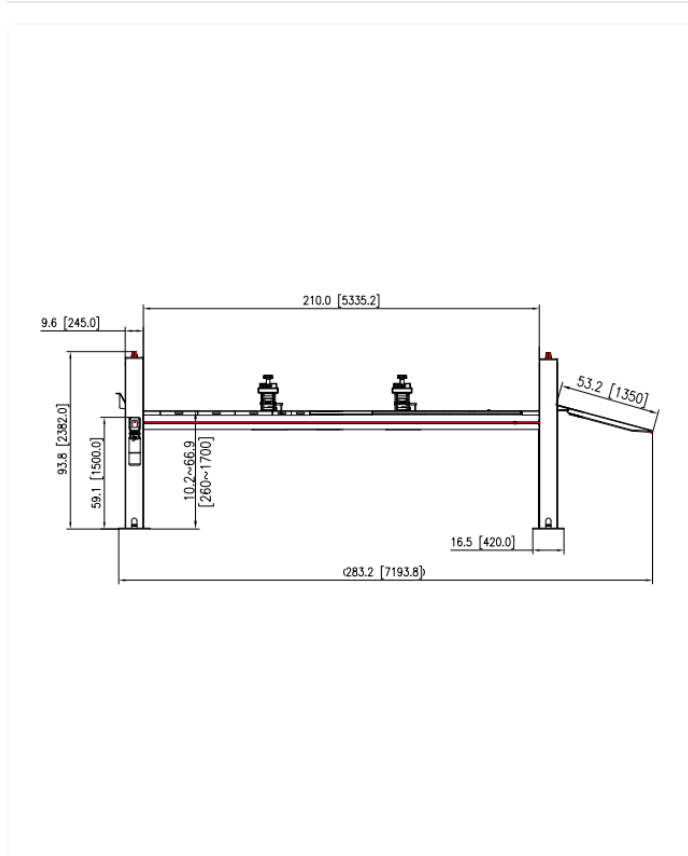

DIMENSIONS, COLOURS AND ITEMS ARE SUBJECT TO CHANGE WITHOUT PRIOR NOTICE DUE TO OUR CONTINUOUS IMPROVEMENT PROGRAM.

