

 ALI CERTIFIED



\* Optional 2-foot height extension kit sold separately.

## PROFESSIONAL GRADE LIFTING

Engineered for professional automotive shops, this 10,000 lb capacity 2-post overhead lift features dual direct-drive cylinders and a versatile 3-stage arm design. **Proudly ALI Certified** to guarantee maximum safety, performance, and reliability.

### IDEAL FOR:

- ✓ Commercial Auto Repair Shops
- ✓ Dealership Service Centers
- ✓ Heavy-Duty Fleet Maintenance

## SYSTEM FEATURES



### Advanced Safety Systems

Equipped with automatic safety locks featuring a single-point lock release system and automatic arm restraints for secure lifting.



### Dual Direct Drive Hydraulics

Powered by robust dual direct-drive hydraulic cylinders, ensuring smooth, reliable, and powerful lifting performance every time.



### Versatile Arm Design

Compact three-stage front and rear arm design allows for both asymmetric and symmetric lifting, accommodating a wide range of vehicles.



### Comprehensive Accessories

Includes two-stage drop-in pads and a complete set of height extensions (1.5", 3" & 6") to reach specialized lifting points.



**ALI CERTIFIED**



Matte Powder Coat Finish



144.5" Overall Height



10,000 lbs Lifting Capacity



3 Adjustable Width Settings



1 Year Warranty



### DISTRIBUTOR PROGRAM

We are looking for distributors and installers in Canada and the USA. Contact us for details.

# SPECIFICATIONS

BR10-20H-33 | 10,000 LBS 2-POST OVERHEAD LIFT

ALI CERTIFIED

## POWER REQUIREMENTS

240V 3HP 12A 1PH 60Hz

## LIFTING CAPACITY

10,000 lbs

## GENERAL DIMENSIONS

|                                    |           |
|------------------------------------|-----------|
| Overall Height (to floor):         | 144.5"    |
| Clearance under arm (full height): | 70"       |
| Min. pad height (down position):   | 4"        |
| Vehicle clearance between arms:    | 113"      |
| Post Dimensions:                   | 7" x 12"  |
| Post Base Dimensions:              | 18" x 18" |

## 3 ADJUSTABLE WIDTH SETTINGS

| Setting | Overall | Inside Cols. | Drive-Thru |
|---------|---------|--------------|------------|
| Narrow  | 140.43" | 111.42"      | 88.15"     |
| Medium  | 146.34" | 117.32"      | 94.06"     |
| Wide    | 152.24" | 123.23"      | 99.96"     |

## SHIPPING INFORMATION

**Main Lift:** 142" x 23" x 44" | 2,010 lbs

*(Pump attached to lift. Included in dimensions)*

**Optional Height Kit:** 31" x 18" x 17" | 180 lbs

## EQUIPMENT PROFILE & CLEARANCES

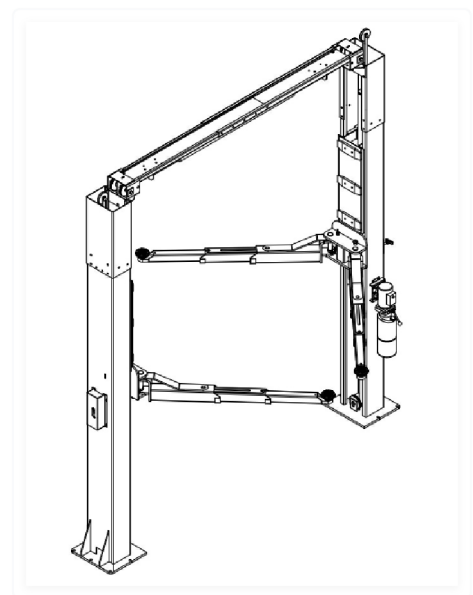
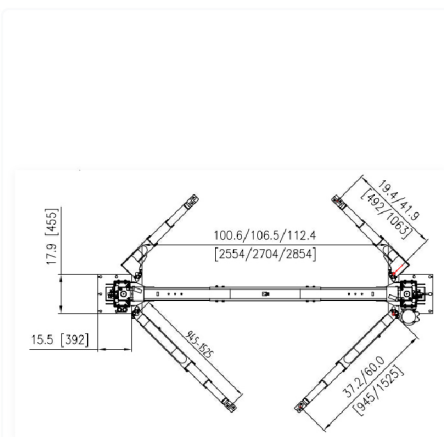
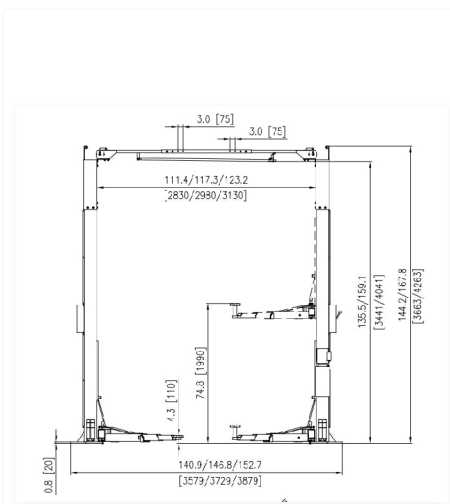

SAFETY COVER WITH HANDLES REQUIRES 9" OF SPACE TO OPERATE. DIMENSIONS AND ITEMS ARE SUBJECT TO CHANGE.



101 Applewood Dr, Brighton, ON K0K1H0

1-866-219-9991 / 613-475-5400

customer@daytonaproducts.com

www.daytonaproducts.com