

Daytona

Daytona Automotive Equipment
Supplier of quality affordable automotive equipment



Daytona Automotive Products

101 Applewood Dr Brighton ON K0K1H0

Canada: 1-866-219-9991 / 613-475-5400

USA: 1-800-359-9322 / 1-440-478-3665

CustomerCare@daytonaproducts.com











www.DaytonaProducts.com

Daytona

LTPF9-SHU 9K Floorplate Lift



Features

-  9,000 lb lifting capacity
-  Automatic safety locks, with single point lock release system
-  High polymer polyethylene wear resistant slide blocks
-  Dual direct drive dual 6' cylinders with cable equalization
-  3-Stage screw up pads
-  Height limit switch
-  Rubber door guards
-  Powder coat finish for durability
-  Three stage front arms
-  Truck adapters standard

Daytona

LTPF9-SHU 9K Floorplate Lift

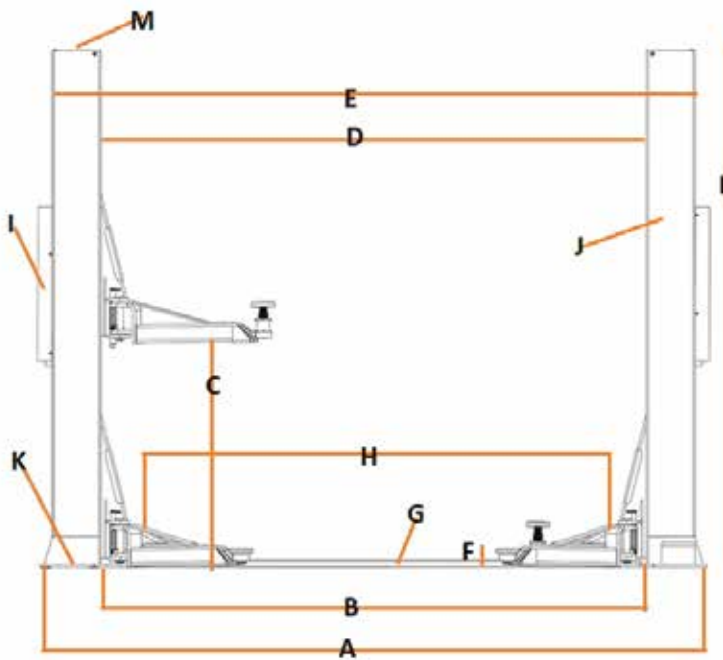

Specifications

Power - 220V, 1Ph, 60Hz

A - Outer width from post base outsides - 136.5"

B - Inner width from base insides - 104"

C - Clearance under arm at full height - 67"

D - Inner width between posts - 112.5"

E - Outer width from posts outsides - 126.5"

F - Minimum clearance height of arms in the down position - 3.75"

G - Floor plate dimensions - 2.5" H x 10.5" W

H - Vehicle Clearance space in between arms - 99"

I - Box with knob requires 9.5" of space to operate

J - Post dimensions - 7" x 11.5"

K - Post Bases dimensions - 16" x 21"

L - Top to Floor - 111.5"

M - Carriage protrudes at full lifting height - 3.5"

DIMENSIONS, COLOURS AND ITEMS ARE SUBJECT TO CHANGE WITHOUT PRIOR NOTICE DUE TO OUR CONTINUOUS IMPROVEMENT PROGRAM

101 Applewood Dr Brighton ON K0K1H0

Canada: 1-866-219-9991 / 613-475-5400

USA: 1-800-359-9322 / 1-440-478-3665

CustomerCare@daytonaproducts.com

www.DaytonaProducts.com











Daytona

LTPO10-SHU

10k Overhead Lift
with 2 posts



Features

-  10,000 lbs lifting capacity with arms fully extended
-  Automatic safety locks, with single point lock release system
-  High polymer polyethylene wear resistant slide blocks
-  Dual direct drive dual 6' cylinders with cable equalization
-  3-Stage screw up pads
-  Height limit switch
-  Rubber door guards
-  Powder coat finish for durability
-  Three stage front arms
-  Truck adapters standard

Daytona

LTPO10-SHU

10k Overhead Lift with 2 posts

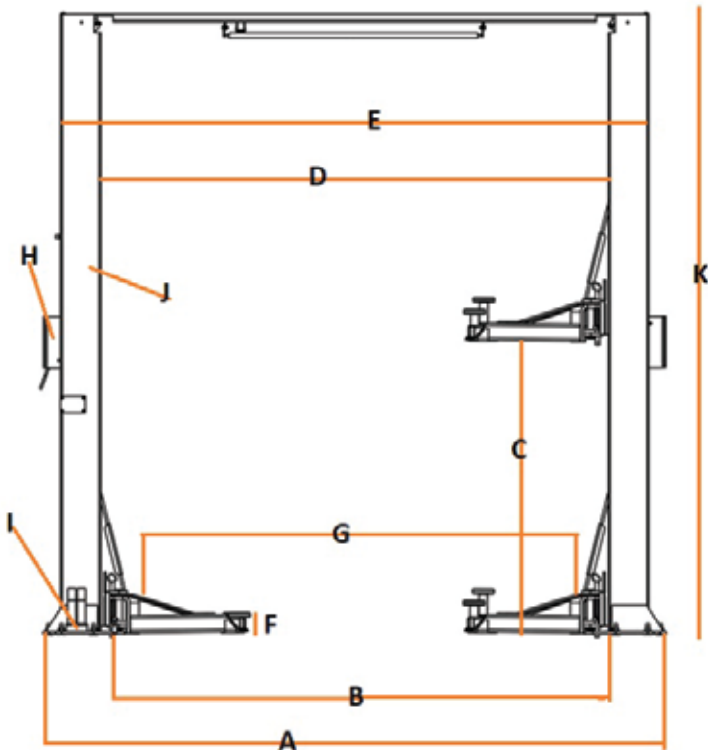

DIMENSIONS, COLOURS AND ITEMS ARE SUBJECT TO CHANGE WITHOUT PRIOR NOTICE DUE TO OUR CONTINUOUS IMPROVEMENT PROGRAM

Specifications

Power - 220V, 1Ph, 60Hz

A - Outer width from post base outsides - 142"

B - Inner width from base insides - 109"

C - Clearance under arm at full height - 70"

D - Inner width between posts - 119"

E - Outer width from posts outsides - 133.5"

F - minimum clearance height of arms in the down position - 3.75"

G - Vehicle Clearance space in between arms - 105"

H - Box with knob requires 5" of space to operate

I - Post Base dimensions - 16" x 21"

J - Post dimensions - 7" x 11.5"

K - Height including overhead bar to floor - 154"

101 Applewood Dr Brighton ON K0K1H0

Canada: 1-866-219-9991 / 613-475-5400

USA: 1-800-359-9322 / 1-440-478-3665

CustomerCare@daytonaproducts.com

www.DaytonaProducts.com

Daytona



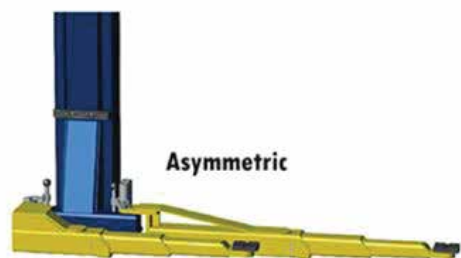



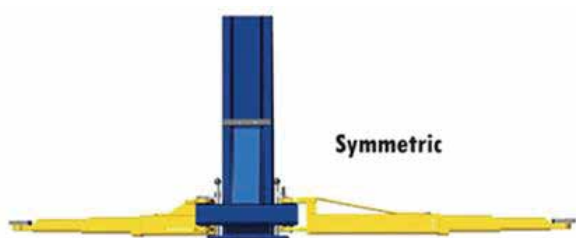



BR10-20H-33 10K ALI CERTIFIED LIFT



Asymmetric & Symmetric
Three Stage Arms



Features

-  Automatic safety locks, with single point lock release system
-  Automatic arm restraints
-  Dual direct drive hydraulic cylinders
-  Compact three stage front and rear arm design allows for asymmetric & symmetric lifting
-  Height extensions included - 1.5", 3" & 6"
-  Matte powder coat finish
-  Two stage drop in pads
-  Three stage front and back arms
-  ALI CERTIFIED
-  1 Year warranty

Please Note: Optional Height Extension Kit is Sold Separately

Daytona

BR10-20H-33 10K ALI CERTIFIED LIFT

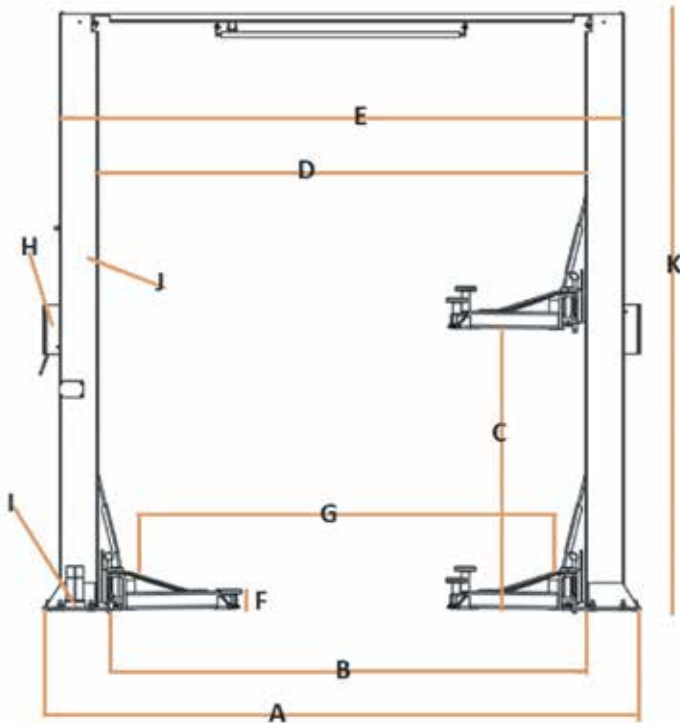

DIMENSIONS, COLOURS AND ITEMS ARE SUBJECT TO CHANGE WITHOUT PRIOR NOTICE DUE TO OUR CONTINUOUS IMPROVEMENT PROGRAM

Specifications

Power - 220V 1Ph 60Hz

A - Outer width from post base outsides - 154"

B - Inner width from base insides - 118"

C - Clearance under arm at full height - 70"

D - Inner width between posts - 123.5"

E - Outer width from posts outsides - 137.5"

F - minimum clearance height of arms in the down position - 4"

G - Vehicle Clearance space in between arms - 113"

H - Box with knob requires 9" of space to operate

I - Post Base dimensions - 18" x 18"

J - Post dimensions - 7" x 12"

K - Height including overhead bar to floor - 144.5"
(not including optional 2' foot height extension kit)

101 Applewood Dr Brighton ON K0K1H0

Canada: 1-866-219-9991 / 613-475-5400

USA: 1-800-359-9322 / 1-440-478-3665

CustomerCare@daytonaproducts.com







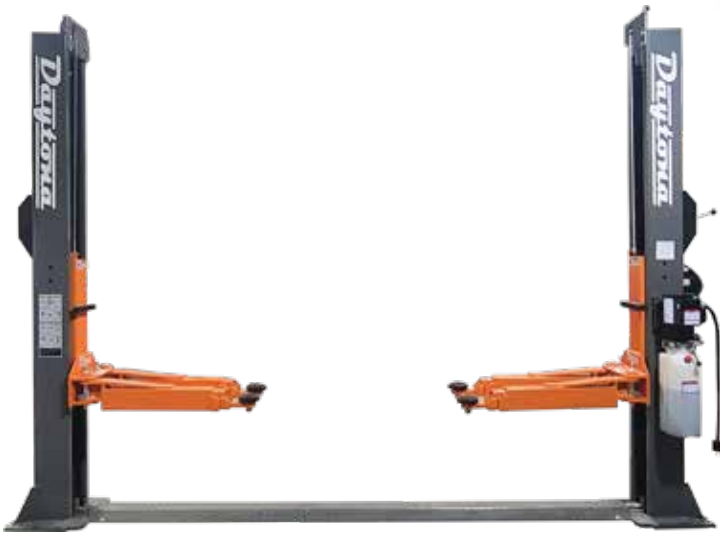



www.DaytonaProducts.com

Daytona

LTPF12-SHU 12K FLOORPLATE LIFT



Features

-  12,000 lb lifting capacity
-  Automatic safety locks, with single point lock release system
-  High polymer polyethylene wear resistant slide blocks
-  Dual direct drive dual 6' cylinders with cable equalization
-  3-Stage screw up pads
-  Height limit switch
-  Rubber door guards
-  Powder coat finish for durability
-  Three stage front arms
-  Truck adapters standard

Daytona

LTPF12-SHU 12K FLOORPLATE LIFT

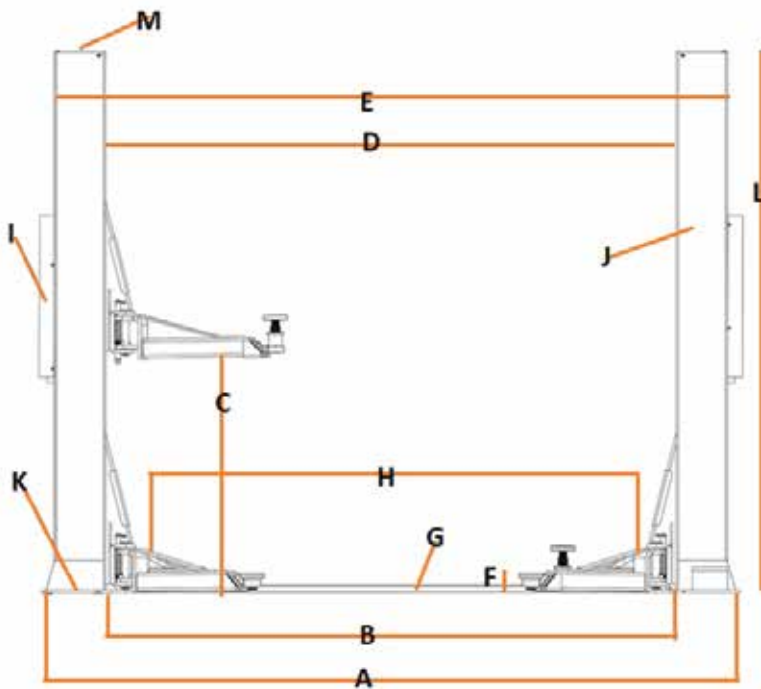

Specifications

Power - 220V, 1Ph, 60Hz

A - Outer width from post base outsides - 156"

B - Inner width from base insides - 122"

C - Clearance under arm at full height - 70.5"

D - Inner width between posts - 131"

E - Outer width from posts outsides - 147"

F - Minimum clearance height - 3.75"

G - Dimensions of floor plate cover - 2.5" H x 10.5" W

H - Vehicle Clearance space in between arms - 118"

I - Box cover with knob requires 11" of space to operate

J - Post dimensions - 8" x 11"

K - Post Bases dimensions - 17" x 21.5"

L - Top to Floor - 116"

M - Carriage protrudes at full lifting height - 7"

DIMENSIONS, COLOURS AND ITEMS ARE SUBJECT TO CHANGE WITHOUT PRIOR NOTICE DUE TO OUR CONTINUOUS IMPROVMENT PROGRAM

101 Applewood Dr Brighton ON K0K1H0

Canada: 1-866-219-9991 / 613-475-5400

USA: 1-800-359-9322 / 1-440-478-3665

CustomerCare@daytonaproducts.com

www.DaytonaProducts.com











Daytona

LTP012-SHU

12K Overhead
2 post lift



Features

-  12,000 lb lifting capacity
-  Automatic safety locks, with single point lock release system
-  High polymer polyethylene wear resistant slide blocks
-  Dual direct drive dual 6' cylinders with cable equalization
-  3-Stage screw up pads
-  Height limit switch
-  Rubber door guards
-  Powder coat finish for durability
-  Three stage front and back arms
-  Truck adapters standard

Daytona

LTPO12-SHU 12K Overhead 2 post lift

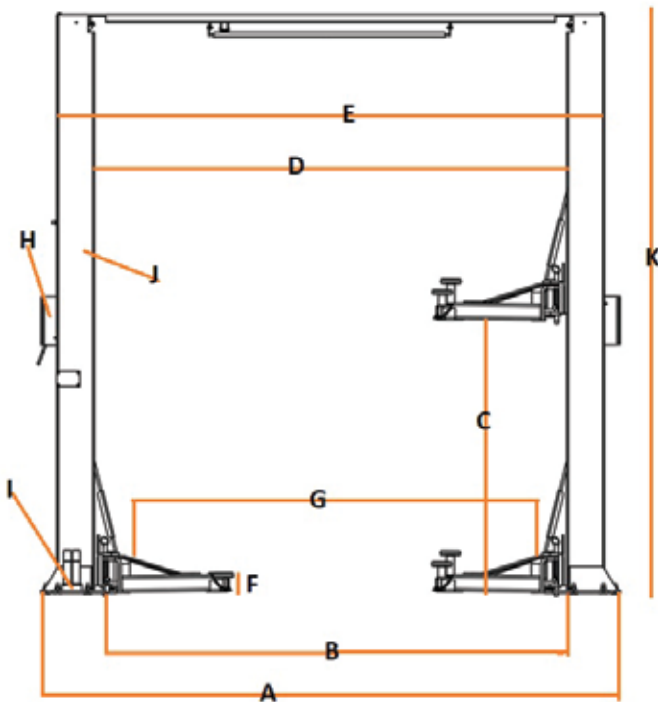

Specifications

Power - 220V, 1Ph, 60Hz

- A - Outer width from post base outsides - 144"
- B - Inner width from base insides - 111"
- C - Clearance under arm at full height - 70"
- D - Inner width between posts - 119.5"
- E - Outer width from posts outsides - 134"
- F - Minimum clearance height of arms in the down position - 3.75"
- G - Vehicle Clearance space in between arms - 108"
- H - Box with knob requires 11" of space to operate
- I - Post Base dimensions - 16" x 21.25"
- J - Post dimensions - 7" x 11.5"
- K - Height including overhead bar to floor - 154"

DIMENSIONS, COLOURS AND ITEMS ARE SUBJECT TO CHANGE WITHOUT PRIOR NOTICE DUE TO OUR CONTINUOUS IMPROVMENT PROGRAM

101 Applewood Dr Brighton ON K0K1H0
Canada: 1-866-219-9991 / 613-475-5400
USA: 1-800-359-9322 / 1-440-478-3665
CustomerCare@daytonaproducts.com
www.DaytonaProducts.com









Daytona

HFPP208-TOR 8k Portable 4 Post Parking Lift



Features

-  Ladder lock system
-  Commercial grade synchronizing safety latch system
-  Air locking system - requires air supply
-  Removeable tilting Steel approach ramp
-  Large heavy duty 3" cylinder
-  Aircraft quality lifting cables
-  Matted powder coat finish

Please Note: Optional Rolling Jacks and Wheel Kits are sold separately. Our 8,000lb Parking lift comes with 1 steel jack tray and 3 plastic drip trays

Daytona

HFPP208-TOR 8k Portable 4 Post Parking Lift

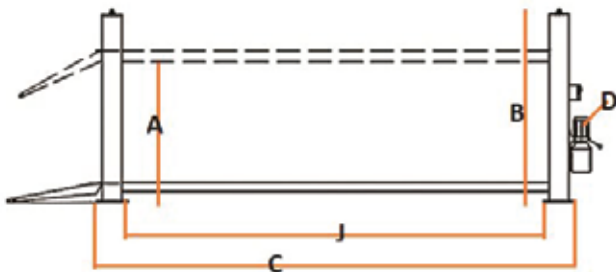
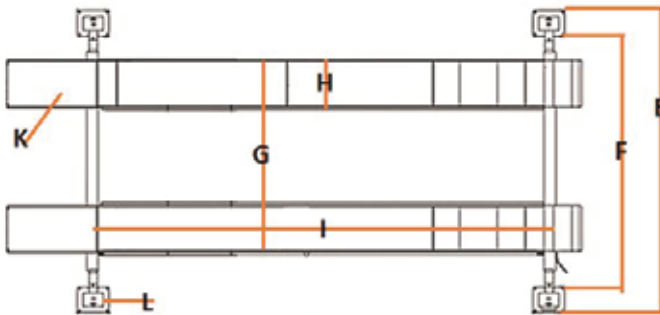

Specifications

Power - 110V, 1PH, 20AMP

Rise Time - 60s

Drop Time - 45s

Post Dimensions - 5" x 6"

Post Bases - 10.5" x 12"

A - Clearance under runway at full height - 71"

B - Overall Height - 89"

C - Overall Length including Posts Bases - 173.5"

D - Pump sticks out 12" from Post

E - Overall width including Posts Bases - 122"

F - Inner width inside Posts - 107"

G - Runway span - 76". Add 6" for Wide Setting.

H - Runway width - 19"

I - Runway length - 170.5"

J - Inner length inside Posts - 155.5"

K - Ramp Dimensions - 34" x 19"

L - Post Dimensions - 5" x 6" Post Bases - 10.5" x 12"

DIMENSIONS, COLOURS AND ITEMS ARE SUBJECT TO CHANGE WITHOUT PRIOR NOTICE DUE TO OUR CONTINUOUS IMPROVEMENT PROGRAM

101 Applewood Dr Brighton ON K0K1H0

Canada: 1-866-219-9991 / 613-475-5400

USA: 1-800-359-9322 / 1-440-478-3665

CustomerCare@daytonaproducts.com

www.DaytonaProducts.com



Daytona

LFPP10-YON 10k 4 Post Parking Lift



Features



Four mechanical locking devices, each equipped with both primary and secondary safety locks



Single point manual safety release



Removeable tilting Steel approach ramp



Large heavy duty 3" cylinder



Aircraft quality lifting cables



Matted powder coat finish

Please Note: Optional Rolling Jacks and Wheel Kits are sold separately. Our 10,000lb Parking lift comes with 1 steel jack tray and 4 steel drip trays

Daytona

LFPP10-YON 10k 4 Post Parking Lift

Specifications

Power - 110V, 1PH, 20AMP

Rise Time - 90s
Drop Time - 60s

Post Dimensions - 5" x 6"

Post Bases - 12" x 12"

Approach Ramp Dimensions - 37" x 19.5"

A - Clearance under runway at full height - 77"

B - Overall Height - 96"

C - Overall Length including Posts Bases - 197.5"

D - Pump sticks out 13" from Post

E - Overall width including Posts Bases - 126.5"

F - Inner width inside Posts - 113"

G - Runway span - 82.5"

H - Runway width - 18.5"

I - Runway length - 182"

J - Inner length inside Posts - 179"

K - Approach Ramp Dimensions - 34" x 19"

L - Post Dimensions - 5" x 6" Post Bases - 12" x 12"

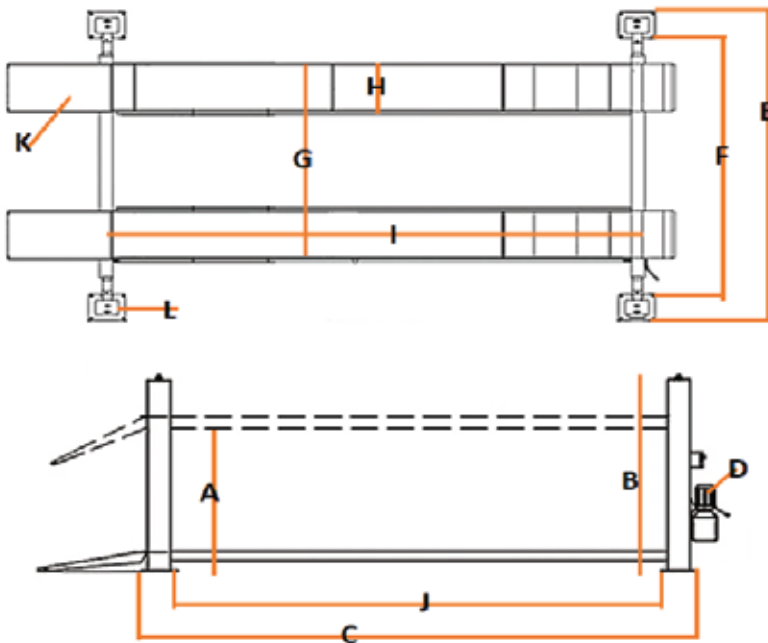

DIMENSIONS, COLOURS AND ITEMS ARE SUBJECT TO CHANGE WITHOUT PRIOR NOTICE DUE TO OUR CONTINUOUS IMPROVMENT PROGRAM







101 Applewood Dr Brighton ON K0K1H0
Canada: 1-866-219-9991 / 613-475-5400
USA: 1-800-359-9322 / 1-440-478-3665
CustomerCare@daytonaproducts.com
www.DaytonaProducts.com

Daytona

LFPA12-LIS 12K Allignment Lift



Features

-  Ladder lock system with manual release for vehicle alignment
-  Commercial grade synchronizing safety latch system
-  Tilting approach ramps in bright Orange
-  Large heavy duty 5" cylinder
-  Aircraft quality lifting cables
-  Matted powder coat finish in dark Grey
-  Built in slip plates and adjustable turntables

Please Note: Lift only - Wheel Alignment Machine Sold Separately Rolling Jack is Sold Separately.

Daytona

LFPA12-LIS 12K Alignment Lift

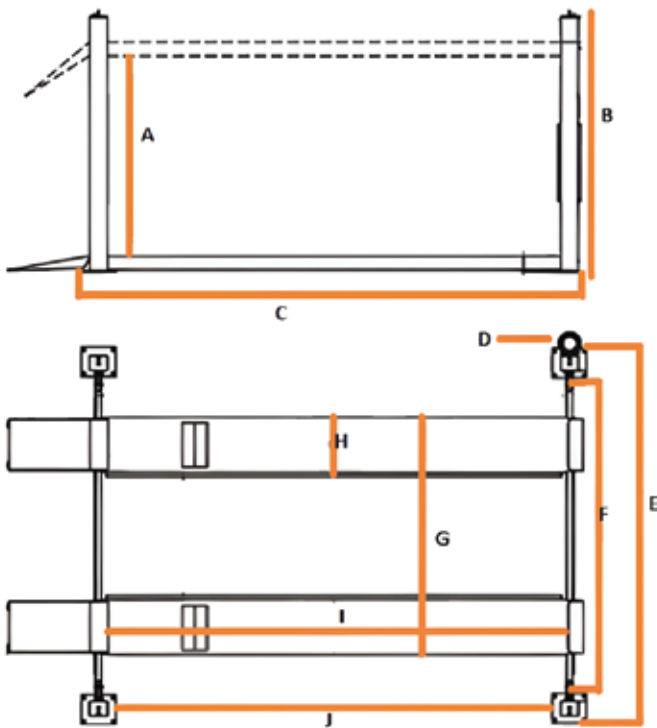

Specifications

Power - 220V, 1PH, 20AMP

Rise Time - 110s

Drop Time - 110s

Post Dimensions - 9.75" x 6.75"

Post Bases - 13.5" x 16.5"

Approach Ramp Dimensions - 54.5" x 23.5"

A - Clearance under runway at full height - 69"

B - Overall Height - 101"

C - Overall Length including Posts Bases - 236.5"

D - Pump sticks out 14" from Post

E - Overall width including Posts Bases - 143.5"

F - Inner width inside Posts - 125"

G - Runway span - 95"

H - Runway width - 25.5"

I - Runway length - 217.25"

J - Inner length inside Posts - 210.25"

DIMENSIONS, COLOURS AND ITEMS ARE SUBJECT TO CHANGE WITHOUT PRIOR NOTICE DUE TO OUR CONTINUOUS IMPROVMENT PROGRAM

101 Applewood Dr Brighton ON K0K1H0

Canada: 1-866-219-9991 / 613-475-5400

USA: 1-800-359-9322 / 1-440-478-3665

CustomerCare@daytonaproducts.com







www.DaytonaProducts.com

Daytona

LFPA14-LIS 14k Alignment Lift



Features

-  Ladder lock system with manual release for vehicle alignment
-  Commercial grade synchronizing safety latch system
-  Tilting approach ramps in bright Orange
-  Large heavy duty 5" cylinder
-  Aircraft quality lifting cables
-  Matted powder coat finish in dark Grey
-  Built in slip plates and adjustable turntables

Please Note: Lift only - Wheel Alignment Machine Sold Separately Rolling Jack is Sold Separately.

Daytona

LFPA14-LIS 14K Allignment Lift

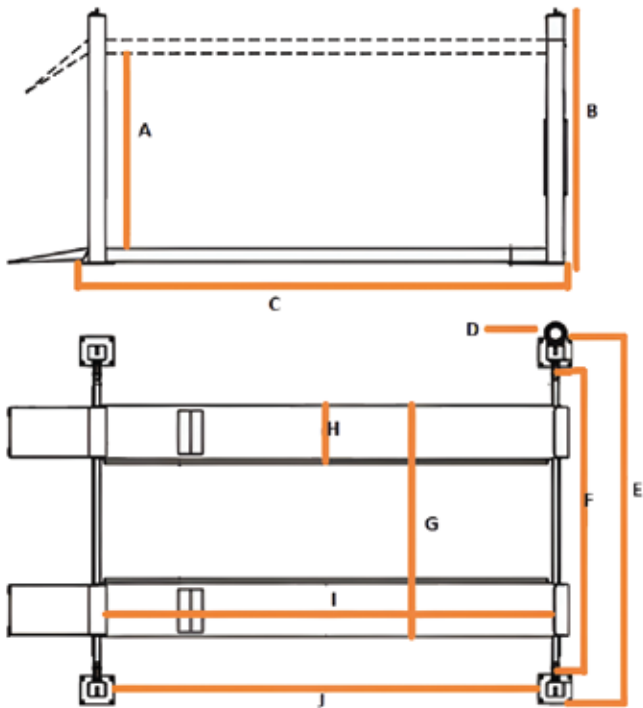

DIMENSIONS, COLOURS AND ITEMS ARE SUBJECT TO CHANGE WITHOUT PRIOR NOTICE DUE TO OUR CONTINUOUS IMPROVMENT PROGRAM

Specifications

Power - 220V, 1PH, 20AMP

Rise Time - 110s

Drop Time - 110s

Post Dimensions - 9.75" x 6.75"

Post Bases - 13.5" x 16.5"

Approach Ramp Dimensions - 54.5" x 23.5"

A - Clearance under runway at full height - 69"

B - Overall Height - 101"

C - Overall Length including Posts Bases - 236.5"

D - Pump sticks out 14" from Post

E - Overall width including Posts Bases - 143.5"

F - Inner width inside Posts - 125"

G - Runway span - 95"

H - Runway width - 25.5"

I - Runway length - 236"

J - Inner length inside Posts - 229.5"

101 Applewood Dr Brighton ON K0K1H0

Canada: 1-866-219-9991 / 613-475-5400

USA: 1-800-359-9322 / 1-440-478-3665

CustomerCare@daytonaproducts.com

www.DaytonaProducts.com



Daytona

HMC1000-TOR Motorcycle Lift



Features



1,000 lb lifting capacity



Automatic safety locks, with durable checker plated design

Dimensions

Lifting Height - 33"

Minimum Height - 7.5"

Table size - 97" x 48"

Longest length including ramp - 118"

Middle section width - 24"

Removable sides (each) - 12"

101 Applewood Dr Brighton ON K0K1H0

Canada: 1-866-219-9991 / 613-475-5400

USA: 1-800-359-9322 / 1-440-478-3665

CustomerCare@daytonaproducts.com



www.DaytonaProducts.com

Daytona

HMC1500B-TOR Motorcycle Lift



Features

-  1500 lb lifting capacity
-  Automatic safety locks, with durable checker plated design

Dimensions

Lifting Height - 33"
Minimum Height - 7"
Table size - 76" x 48"
Middle section width - 28"
Removable sides (each) - 10"
Longest length including ramp - 97"





101 Applewood Dr Brighton ON K0K1H0
Canada: 1-866-219-9991 / 613-475-5400
USA: 1-800-359-9322 / 1-440-478-3665
CustomerCare@daytonaproducts.com
www.DaytonaProducts.com

Daytona

LMS6-SHU Mid-rise Scissor Lift



Features

-  Double cylinder design
-  Pneumatic safety lock
-  Powder coated for strength and durability
-  Height extensions included
-  Ultrathin design for low vehicles and storage

Specifications

Lifting Capacity 6,000lbs
Lifting Height 47.24"
Min. Height 6.5"
Total Width 42.91"
Total Length 66.9"
Power supply 110V

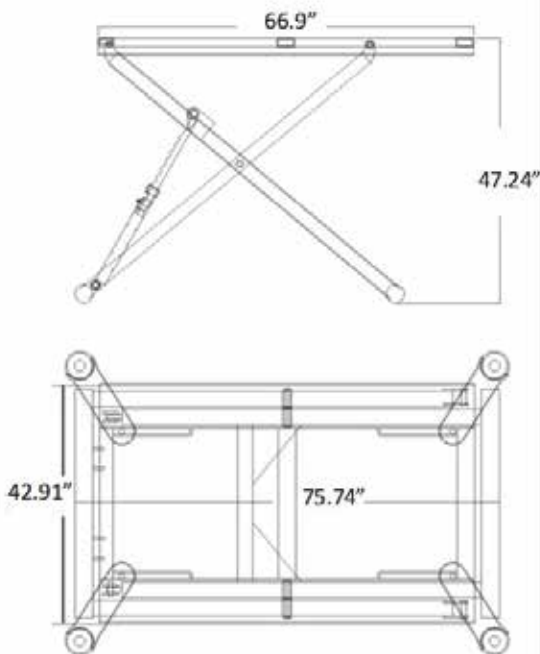





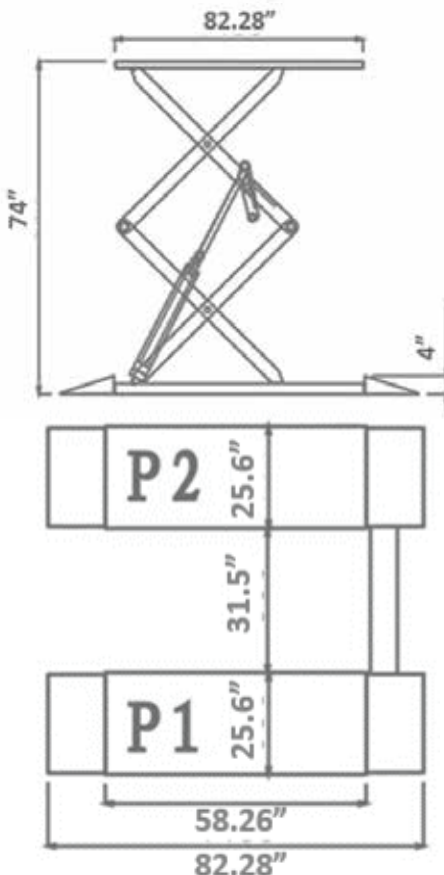

101 Applewood Dr Brighton ON K0K1H0
Canada: 1-866-219-9991 / 613-475-5400
USA: 1-800-359-9322 / 1-440-478-3665
CustomerCare@daytonaproducts.com
www.DaytonaProducts.com

Daytona

LMS7-SHU High Rise Scissor



Features

-  Double Hydraulic Equalizing System
-  Solid steel construction ensures strength and safety
-  Mechanical safety lock with automatic unlock
-  Ramp doubles as extension
-  Powder coated finish for long lasting durability
-  Low profile - Lowered height of 4"

Specifications

- Lifting Capacity - 6,600lbs
- Lifting Height - 74"
- Min. Height - 4"
- Total Width - 82.80"
- Platform Width - 25.59"
- Total Length - 58.26" - 82.28"
- Power supply - 220V

101 Applewood Dr Brighton ON K0K1H0
Canada: 1-866-219-9991 / 613-475-5400
USA: 1-800-359-9322 / 1-440-478-3665
CustomerCare@daytonaproducts.com
www.DaytonaProducts.com

Daytona

TC-880-BRI

Tire Changer Base Model









Accessories

Space Requirement
44"W x 46" D x 72"H

Specifications

Inside Rim clamping - 10" - 22"
Outside Rim clamping - 12" - 24"
Max Wheel diameter - 38"
Max tire width - 10"
Air-Pressure - 120 -145PSI
Power - 120V

Features

-  Swing arm style
-  Manual operation of mount/demount tool
-  Four pneumatic clamps and double acting cylinders
-  Side mounted bead breaker
-  Integrated bead seating jets in the clamps
-  Includes water separator, lubricator and air pressure regulator

101 Applewood Dr Brighton ON K0K1H0
Canada: 1-866-219-9991 / 613-475-5400
USA: 1-800-359-9322 / 1-440-478-3665
CustomerCare@daytonaproducts.com
www.DaytonaProducts.com



Daytona

TC-814-YUH

Tire Changer Base Model



Space Requirement
48"W x 44" D x 77"H

Specifications

Inside Rim clamping - 14 - 24"
Outside Rim clamping - 12" - 22"
Max Wheel diameter - 42"
Max tire width - 12"
Air-Pressure - 120 -145PSI
Power - 1.1Kw/120V
Weight - 482.8lbs

Features



24" working plate



The strong stainless steel working tire assembly head prevents ractures and deformation



Special explosion-proof grade oil mist device keeps the pressureresistance consistent



Using the pure copper brand motor, the torque can reach sufficient power of 1200-1500nm



Advanced burst structure, with column gas storage makes this machine safe & efficient.



On board air reservoir featuring handheld bead blaster



Pneumatic dismount head lock



Comes with rim clamp protector, dismount head protector, and rim slip applicator



Comes with bead breaker rim protector

101 Applewood Dr Brighton ON K0K1H0
Canada: 1-866-219-9991 / 613-475-5400
USA: 1-800-359-9322 / 1-440-478-3665
CustomerCare@daytonaproducts.com
www.DaytonaProducts.com







Daytona

TC-890-BRI

Tire Changer Mid-Size Model



Features

-  Heavy Duty tire changer safely handles most types of rims
-  Handles stiff, wide and low profile tires with ease
-  Self-centering device
-  Pneumatic bead breaker system
-  Rim Clamp rubber shoes included to protect chrome rims
-  Adjustable inflating device

Specifications

- Rim Size - 10" - 24"
- Rim clamping from outside - 12" - 24"
- Rim clamping from inside - 10" - 21"
- Bead-breaker force Maximum - 2.75 tons/ 2,500 kg
- Wheel diameter - 40" | 1,000 mm
- Wheel Width - 3" - 15"
- Air Pressure - 120 - 145 psi
- Net Weight - lbs/ 360 kg
- Table Motor - 1.5HP/1KW 120
- Operating Voltage - V / 60 Hz

Additional Features

- Oversized bead seating air blaster
- Efficient mounting and demounting with the air operated bead lifting and pressing feature
- Air Lubricator and Air Filter included
- Water trap and Air Regulator included
- Soap Reservoir included

101 Applewood Dr Brighton ON K0K1H0
Canada: 1-866-219-9991 / 613-475-5400
USA: 1-800-359-9322 / 1-440-478-3665
CustomerCare@daytonaproducts.com
www.DaytonaProducts.com

Daytona

TC-886-YUH Tire Changer Mid-Size Model











Space Requirements
82"W x 48"D x 76"H

Specifications

Inside rim clamping - 14"-26"
Outside rim clamping - 11"-24"
Max wheel diameter - 42"
Max tire width - 12"
Air Pressure - 120-145PSI
Power - 1.1Kw/120V

Features

-  The strong stainless steel working tire assembly head prevents fractures and deformation
-  Pneumatic dismount head lock
-  The mechanical arm is made from a high strength pure steel casting, and embedded with wear resistant sliding blocks making the mechanical arm run smoothly.
-  Special explosion-proof grade oil mist device keeps the pressure resistance consistent
-  Included bead breaker rim protector, rim clamp protector, dismount head protectors and rim slip applicator
-  Using the pure copper brand motor, the torque can reach sufficient power of 1200-1500nm
-  On board air reservoir featuring handheld blaster
-  Other features include, aluminum control lock, oil-water separator for exporting, enhanced bead breaker arm, aluminum foot treadle, iron hexagonal bar cap, numerical air inflation indicator, and pressure meter

101 Applewood Dr Brighton ON K0K1H0
Canada: 1-866-219-9991 / 613-475-5400
USA: 1-800-359-9322 / 1-440-478-3665
CustomerCare@daytonaproducts.com
www.DaytonaProducts.com



Daytona

TC-890T-BRI Tilt Tire Changer Heavy Duty Model



Space Requirements

66"W x 69" D x 79"H

Specifications

Inside rim clamping - 13"-28"

Outside rim clamping - 13"-26"

Bead Breaker force - 2.75tons/2500kg













Max wheel diameter - 42"

Max tire width - 12"

Air pressure - 120-145PSI

Power - 1.5HP/1Kw/120V

Features

-  Tilting column, pneumatic locking system
-  Heavy duty tire changer safely handles most types of rims
-  Handles stiff, wide and low-profile tires with ease
-  Self centering device
-  Pneumatic bead breaker system
-  Comes with Rim clamp protectors included to protect chrome rims, and dismount head protectors
-  Adjustable inflating device
-  Oversized bead seating air blaster
-  Efficient mounting and demounting with the air operated bead lifting and pressing feature
-  Air lubricator and air filter included
-  Water trap and air regulator included
-  Soap reservoir included

101 Applewood Dr Brighton ON K0K1H0

Canada: 1-866-219-9991 / 613-475-5400

USA: 1-800-359-9322 / 1-440-478-3665

CustomerCare@daytonaproducts.com

www.DaytonaProducts.com

Daytona

TC-825-YUH Heavy Duty Tilt Tire Changer













Space Requirements
64"W x 65"D x 79"H

Specifications

Inside Rim clamping - 14"-26"
Outside Rim clamping - 11"-24"
Rim size - 13"-26"
Max Wheel diameter - 42"
Max Tire Width - 12"
Air Pressure - 120-145PSI
Weight - 950lbs
Power - 1.1Kw/120V

Features

-  The Push and Pull arm is made of high grade powder coated steel, providing high strength and corrosion resistance
-  The adjustable length of the large assist arm makes this machine more suitable for use with larger rim sizes
-  The inflatable pressure limit valve provides controllable inflatable pressure, thus a safer machine
-  Pneumatic dismount head lock
-  The assembly head is made of stainless steel to prevent fracture and deformation
-  This machine can reach sufficient torque at 1200-1500nm
-  Advanced detonation inflatable structure, with column gas storage, makes this machine safe and efficient
-  The mechanical arm has a high strength pure steel casting, embedded with a wear resistant sliding block. Combined with its fine grinding slide, allows the mechanical arm to run smoothly and freely
-  Comes with rim clamp protectors, dismount head protectors, and rim slip applicator
-  Extra roller to help press on the tire to keep it under the dismount head
-  Comes with bead breaker rim protector

Additional Features

Right sided arm assistant, Oil-Water separator for exporting
Enhanced and Extendable bead breaker arm 26" working plate
Stainless steel working head, Aluminum foot treadle
Enhanced base, Smooth bearing, Tool box compartment

101 Applewood Dr Brighton ON K0K1H0
Canada: 1-866-219-9991 / 613-475-5400
USA: 1-800-359-9322 / 1-440-478-3665
CustomerCare@daytonaproducts.com
www.DaytonaProducts.com



Daytona



TC-819-YUH Automatic Centre Mounting Tire Changer











Space Requirements
77"W x 65"D x 80"H

Specifications

Max wheel diameter - 44"
Max tire width - 14"
Air Pressure - 120-145PSI
Weight - 950lbs
Power - 1.1Kw/120V

Features

-  This machine features no outside rim locking structure. Instead, with a center mounting locking system, you get quick locking without damaging the rims
-  Pneumatic dismount head lock
-  This machine is easy to operate with its hand controlled large universal shovel structure
-  This machine features lever-less style dismount head, which eliminates the crowbar, and decreases possibility of damage to the rim and tire
-  Automatic inflation table uses a high end inflation meter, an inlet chip, and preset tire pressure inflation settings, making this machine safe and efficient
-  Special explosion-proof grade oil mist device keeps the pressure resistance consistent
-  The mechanical arm has a high strength pure steel casting, embedded with a wear resistant sliding block. This, combined with its fine grinding square tube, allows the mechanical arm to run smoothly and freely
-  Comes with 4 cones ranging from 1-3/4" to 5.5". Comes with bead breaker rim protector
-  Comes with rim clamp protector, dismount head protector, and rim slip applicator

Additional Features

Hand control bead breaker, Reverse removal feature
Push down plate on Assist Arm, Power assisted handle
Automatic inflation meter, Center rim mount locking
Automatic tire lift, Oil-Water separator

101 Applewood Dr Brighton ON K0K1H0
Canada: 1-866-219-9991 / 613-475-5400
USA: 1-800-359-9322 / 1-440-478-3665
CustomerCare@daytonaproducts.com
www.DaytonaProducts.com

Daytona

BL-930-YUH







Wheel Lift



Space Requirements

34W x 29D x 48H

Features

-  This product is suitable for lifting all kinds of light vehicle tires
-  Bearing track is made from steel aluminum composite
-  Ergonomic switch makes it an easy machine to learn to use and operate
-  Wide tire support panel allows you to carry more
-  Independent oil mist atomizer helps lubricate the air circuit and reduce wear consumption
-  Featuring a unique main frame construction. Easy tire loading on the low tread and smaller rolling gradient required for working with tires
-  Max lifting weight - 165.3lb

101 Applewood Dr Brighton ON K0K1H0
Canada: 1-866-219-9991 / 613-475-5400
USA: 1-800-359-9322 / 1-440-478-3665
CustomerCare@daytonaproducts.com
www.DaytonaProducts.com



Daytona

TC-810-YUH







Tire Turnover Rack



Space Requirements

34W x 29D x 48H

Features

-  This product is for lifting all kinds of light vehicle tires
-  The machine automatically turns the tire to be parallel with the working table
-  No dead angle when rolling
-  Easier to move tires
-  Easy to operate, tire can be lifted or lowered with one foot
-  Equipped with a lifting speed regulating valve
-  Max lifting weight - 165.3lb

101 Applewood Dr Brighton ON K0K1H0
Canada: 1-866-219-9991 / 613-475-5400
USA: 1-800-359-9322 / 1-440-478-3665
CustomerCare@daytonaproducts.com
www.DaytonaProducts.com

Daytona

BL-917-BRI

Wheel Balancer Base Model













Space Requirement
44"W x 50"D x 68"H

Specifications

Cycle time - 10 seconds
Max Wheel Diameter - 35"
Rim width - 1 - 20"
Rim diameter - 9.5 - 24"
Max Wheel weight - 143lbs
Accuracy - 1gr
Power - 120V

Features

-  Self Calibrating
-  On board Sensor Diagnosis and testing
-  ST, DYN, AL 1, AL2, AL3 balancing methods
-  Motorcycle wheel balancing mode
-  On/off hood operation also with hood start mode
-  Weight storage
-  Pegs for accessories
-  6.5" long shaft with 40mm diameter
-  Five auto STD Centering cones
-  Speed nut, hammer and caliper
-  Comes with 4-cones ranging from 1-3/4" to 6- 1/8"

101 Applewood Dr Brighton ON K0K1H0
Canada: 1-866-219-9991 / 613-475-5400
USA: 1-800-359-9322 / 1-440-478-3665
CustomerCare@daytonaproducts.com
www.DaytonaProducts.com

Daytona

BL-937-YUH Base Model Wheel Balancer



Space Requirement
(including wheel cover)
47"W x 37"D x 57"H

Specifications

Rim diameter - 10" - 24"
Max Wheel Diameter - 37.4"
Tire Width - 4" - 16"
Max Tire Weight - 65kg/143.3lbs
Rotation speed - 200r/min
Balance Precision - 1g
Motor - 120V
Weight - 205lbs

Features



This product makes fine adjustments for tires of various sizes, mainly used for light vehicles



High precision balancing shaft can recognize automatic dynamic balance, static balance, and aluminum ally rim balance



The Balancing Shaft is heat treated



Wheel vs Rim optimization with the OPT program



40mm shaft diameter



Rapid clamping nut



Laser light for easy inside wheel weight placement



LED light for easy visibility



Comes with 4 cones ranging from 1-3/4" to 5-1/4". Comes with weight hammer+plier. Comes with calibration weight

101 Applewood Dr Brighton ON K0K1H0
Canada: 1-866-219-9991 / 613-475-5400
USA: 1-800-359-9322 / 1-440-478-3665
CustomerCare@daytonaproducts.com
www.DaytonaProducts.com

Daytona

BL-950-BRI Wheel Balancer Mid-Size Model



Space Requirement
49"W x 54"D x 72"H

Specifications

Cycle time - 7 seconds

Max Wheel Diameter - 39"

Rim width - 1.5 - 24"













Rim diameter - 9.5 - 20"

Max Wheel weight - 150lbs

Accuracy - 1gr

Power - 120V

Features

-  Self Calibrating
-  On board Sensor Diagnosis and testing
-  ST, DYN, AL 1, AL2, AL3 balancing methods
-  Motorcycle wheel balancing mode
-  On/off hood operation also with hood start mode (Hood Included)
-  On/off beep indicator
-  Weight storage
-  Pegs for accessories
-  8" long shaft with 40mm diameter
-  Five auto STD Centering cones
-  Speed nut, hammer and caliper
-  Complete operations manual

101 Applewood Dr Brighton ON K0K1H0
Canada: 1-866-219-9991 / 613-475-5400
USA: 1-800-359-9322 / 1-440-478-3665
CustomerCare@daytonaproducts.com
www.DaytonaProducts.com

Daytona

BL-935-YUH Mid-Size Wheel Balancer



Space Requirement
(including wheel cover)
50"W x 35"D x 51"H

Specifications

Rim diameter - 10" - 24"
Max Wheel Diameter - 37.4"
Tire Width - 4" - 14"
Max Tire Weight - 143.3lbs
Rotation speed - 200r/min
Balance Precision - 1g
Motor - 120V
Weight - 220.5lbs

Features



This product makes fine adjustments for tires of various sizes, mainly used for light vehicles



High precision balancing shaft can recognize automatic dynamic balance, static balance, and aluminum ally rim balance



The Balancing Shaft is heat treated



Wheel vs Rim optimization with the OPT program



The spindle of the wheel balancer, using a 40mm rotating shaft, can be idling, and the accuracy is equally high for heavy tires.



Laser light for easy inside wheel weight placement



LED light for easy visibility



Comes with 4 cones ranging from 1-3/4" to 5-1/4". Comes with weight hammer+plier. Comes with calibration weight

101 Applewood Dr Brighton ON K0K1H0
Canada: 1-866-219-9991 / 613-475-5400
USA: 1-800-359-9322 / 1-440-478-3665
CustomerCare@daytonaproducts.com
www.DaytonaProducts.com

Daytona

BL-956-BRI

Wheel Balancer Heavy Duty Model



Space Requirement
54"W x 44"D x 58"H

Specifications

Max wheel weight - 165lbs

Power - 110V

Balancing accuracy - 1gr

Cycle time - 5-7 seconds















Rim Diameter - 8"-35"

Rim width - 2"-20"

Max Wheel diameter - 44"

Shaft diameter - 40mm x 8.5" long

Features

-  LED touch-panel keypad with easy to read icons assisting operators utilizing all balancing functions
-  Balance up to 44" overall wheel diameter
-  Comes with 4 cones ranging from 1-3/4" to 6-1/8"
-  Multi-Mode Vehicle Balancing standard with SUV, Car & Motorcycle balancing modes
-  At 140 R P M the balancer's life is further extended for sensitive electronics & moving components while providing highly accurate wheel balancing
-  Manual measurement input for distance & diameter with 5 balancing modes including 2 ALU Smart modes
-  Laser Indicator lights up automatically at the unbalance weight position
-  Measurement Acquisition Wand allows for ease of acquiring measurement data with a retractable measuring tool
-  Light Indicator illuminates inside of wheel automatically at the unbalanced weight position
-  Foot Pedal Braking System conveniently secures wheel in the unbalanced position to accurately apply balance wheel weights
-  Speed-Nut Mounting easily secures the wheel to the spindle with convenient lead-in screw
-  Multi-Pocket Wheel Weight Shelf featuring 14 articulated pockets, over 1.5" deep, allowing plenty of storage for weights & tooling
-  The large 38" wheel hood prevents debris from flying off the tire while in use
-  Power Saving Mode automatically puts machine in stand-by mode after 5 minutes of non-usage

101 Applewood Dr Brighton ON K0K1H0

Canada: 1-866-219-9991 / 613-475-5400

USA: 1-800-359-9322 / 1-440-478-3665

CustomerCare@daytonaproducts.com

www.DaytonaProducts.com

Daytona

BL-933-YUH Heavy Duty Wheel Balancer











Space Requirement
(including wheel cover)
38"D x 47"W x 62"H

Specifications

Rim Diameter - 8"-30"
Max Wheel Diameter - 37.4"
Tire Width - 3"-14"
Max Wheel Weight - 143lbs
Rotation speed - 200r/min
Accuracy - 1g
Power - 120V

Features

-  Automatic static balance and dynamic balance with the ALU program and high precision balancing shaft.
-  Automatic Distance Ruler - pull out the distance ruler and hear the sound, the control panel automatically displays the data
-  Ultrasonic probe
-  Variety of balancing programs suitable for different wheel structures
-  HTD Program is split to hide weight behind the spokes
-  Wheel vs Rim optimization with the OPT program
-  Easy to detect and solve problems with the fault diagnosis system which checks the working status of key components
-  Automatic locating with the automatic electromagnetic brake function
-  Has a standard anti-positioning function

101 Applewood Dr Brighton ON K0K1H0
Canada: 1-866-219-9991 / 613-475-5400
USA: 1-800-359-9322 / 1-440-478-3665
CustomerCare@daytonaproducts.com
www.DaytonaProducts.com



Daytona

BL-936-YUH Advanced Model Wheel Balancer













Space Requirement
(including wheel cover)
49"W x 45"D x 65"H

Specifications

Rim Diameter - 10"-24"
Max Wheel Diameter - 37.4"
Tire Width - 4"-16"
Max Tire Weight - 143.3lbs
Rotation speed - 200r/min
Balance Precision - 1g
Motor - 120V
Weight - 242.5lbs

Features

-  Liquid Crystal 21" LCD display
-  Automatic static balance and dynamic balance with the ALU program and high precision balancing shaft
-  Automatic Distance Ruler - pull out the distance ruler and the control panel automatically displays the data
-  Ultrasonic sensor for rim width
-  Variety of balancing programs suitable for different wheel structures
-  HTD Program is split to hide weight behind the spokes
-  Wheel vs Rim optimization with the OPT program
-  Easy to detect and solve problems with the fault diagnosis system which checks the working status of key components
-  Automatic locating with the automatic electromagnetic brake function
-  Laser light for easy inside wheel weight placement
-  Comes with 4 cones ranging from 1-3/4" to 5-1/4". Comes with weight hammer+plier. Comes with calibration weight.

101 Applewood Dr Brighton ON K0K1H0
Canada: 1-866-219-9991 / 613-475-5400
USA: 1-800-359-9322 / 1-440-478-3665
CustomerCare@daytonaproducts.com
www.DaytonaProducts.com